

# Product Specification

**Ord.-No.:** **111 424 S1**

**Specification:** Connecting clamp, with bracket, V2A  
Ø 6-20 reinforcement / fl. 30 or Ø 10 mm

**Performance:** Connecting clamp with clamping bracket (JP/type A) according to DIN EN 62561-1 for the connection of round and flat conductors with the reinforcement in the concrete foundation.

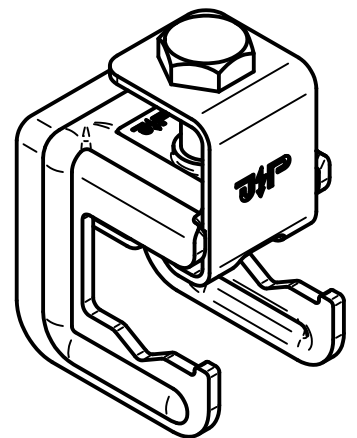
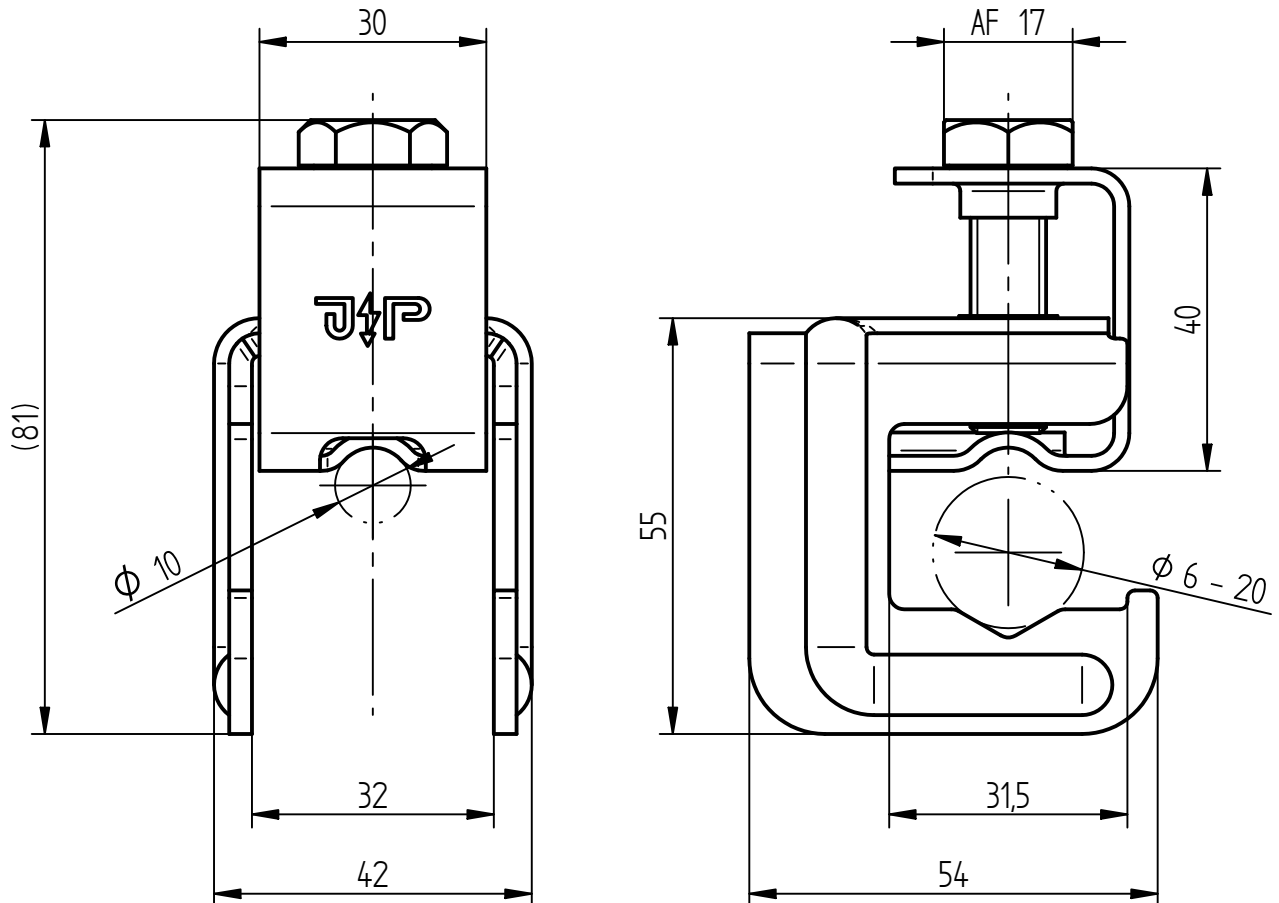

Material	Stainless steel V2A
Type of clamp	flat or round on reinforcement
Fit	fl. 30 mm or Ø 10 mm/Ø 6-20 mm
Alternative fit	flat on flat, fl. 30 mm/fl. 30 mm
Screw	Hexagon bolt M10, Stainless steel V2A
Weight	212 g
Standard reference	DIN EN 62561-1
Packing unit	25 units